

# 560

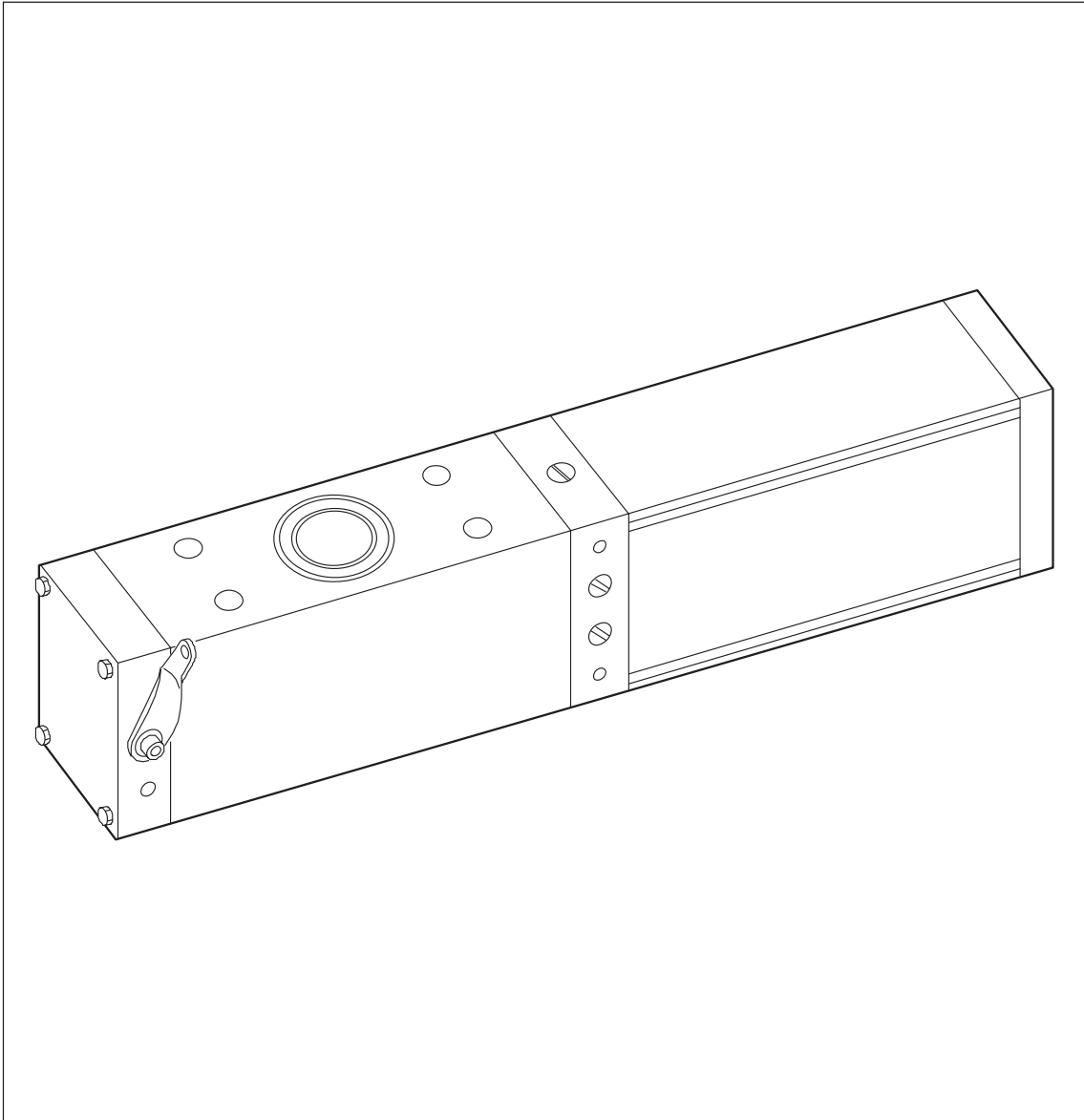

# FAAC

## EC DECLARATION OF CONFORMITY FOR MACHINES (DIRECTIVE 98/37/EC)

**Manufacturer:** FAAC S.p.A.

**Address:** Via Benini, 1 - 40069 Zola Predosa BOLOGNA - ITALY

**Declares that:** 560 mod. operator

- is built to be integrated into a machine or to be assembled with other machinery to create a machine under the provisions of Directive 98/37/EC;
- conforms to the essential safety requirements of the following EEC directives:

73/23/EEC and subsequent amendment 93/68/EEC.  
89/336/EEC and subsequent amendment 92/31/EEC and 93/68/EEC

and also declares that it is prohibited to put into service the machinery until the machine in which it will be integrated or of which it will become a component has been identified and declared as conforming to the conditions of Directive 98/37/EC.

Bologna, 01 January 2004

The Managing Director  
A. Bassi

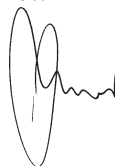

### WARNINGS FOR THE INSTALLER GENERAL SAFETY OBLIGATIONS

- 1) **ATTENTION! To ensure the safety of people, it is important that you read all the following instructions. Incorrect installation or incorrect use of the product could cause serious harm to people.**
- 2) Carefully read the instructions before beginning to install the product.
- 3) Do not leave packing materials (plastic, polystyrene, etc.) within reach of children as such materials are potential sources of danger.
- 4) Store these instructions for future reference.
- 5) This product was designed and built strictly for the use indicated in this documentation. Any other use, not expressly indicated here, could compromise the good condition/operation of the product and/or be a source of danger.
- 6) FAAC declines all liability caused by improper use or use other than that for which the automated system was intended.
- 7) Do not install the equipment in an explosive atmosphere: the presence of inflammable gas or fumes is a serious danger to safety.
- 8) The mechanical parts must conform to the provisions of Standards EN 12604 and EN 12605.  
For non-EU countries, to obtain an adequate level of safety, the Standards mentioned above must be observed, in addition to national legal regulations.
- 9) FAAC is not responsible for failure to observe Good Technique in the construction of the closing elements to be motorised, or for any deformation that may occur during use.
- 10) The installation must conform to Standards EN 12453 and EN 12445.  
For non-EU countries, to obtain an adequate level of safety, the Standards mentioned above must be observed, in addition to national legal regulations.
- 11) Before attempting any job on the system, cut out electrical power.
- 12) The mains power supply of the automated system must be fitted with an all-pole switch with contact opening distance of 3mm or greater. Use of a 6A thermal breaker with all-pole circuit break is recommended.
- 13) Make sure that a differential switch with threshold of 0.03 A is fitted upstream of the system.
- 14) Make sure that the earthing system is perfectly constructed, and connect metal parts of the means of the closure to it.
- 15) The safety devices (EN 12978 standard) protect any danger areas against **mechanical movement Risks**, such as crushing, dragging, and shearing.
- 16) Use of at least one indicator-light (e.g. FAACLIGHT) is recommended for every system, as well as a warning sign adequately secured to the frame structure, in addition to the devices mentioned at point "15".
- 17) FAAC declines all liability as concerns safety and efficient operation of the automated system, if system components not produced by FAAC are used.
- 18) For maintenance, strictly use original parts by FAAC.
- 19) Do not in any way modify the components of the automated system.
- 20) The installer shall supply all information concerning manual operation of the system in case of an emergency, and shall hand over to the user the warnings handbook supplied with the product.
- 21) Do not allow children or adults to stay near the product while it is operating.
- 22) Keep remote controls or other pulse generators away from children, to prevent the automated system from being activated involuntarily.
- 23) Transit through the leaves is allowed only when the gate is fully open.
- 24) The user must not attempt any kind of repair or direct action whatever and contact qualified personnel only.
- 25) Maintenance: check at least every 6 months the efficiency of the system, particularly the efficiency of the safety devices (including, where foreseen, the operator thrust force) and of the release devices.
- 26) **Anything not expressly specified in these instructions is not permitted.**

# AUTOMATED SYSTEM 560

## 1. AUTOMATED SYSTEM 560

The FAAC model 560 operator automates two-leaf folding doors with one operator (fig. 2-4-6) or four-leaf doors (two-leaf units on each side) with two operators (fig. 5).

## 2. GENERAL INFORMATION

The operator 560 consists of an hydraulic enbloc containing an electric motor, a pump and a hydraulic jack. All these elements are enclosed in an anodised aluminium housing of modern, elegant design, which also acts as an oil tank.

It can be fitted on already installed doors or doors to be installed, without any modifications to the structure.

The operator is also suitable for outdoor installation, providing an ordinary plastic or steel sheet housing is provided to protect it against direct contact with atmospheric agents.

Neither a chain nor a rack are necessary to transmit drive. Motion, obtained via a rotating telescopic arm, is silent, smooth and fast. The FAAC 560 automated system consists of a an hydraulic power unit, an electronic control unit and installation accessories. Figure 1 shows the operator's overall dimensions.

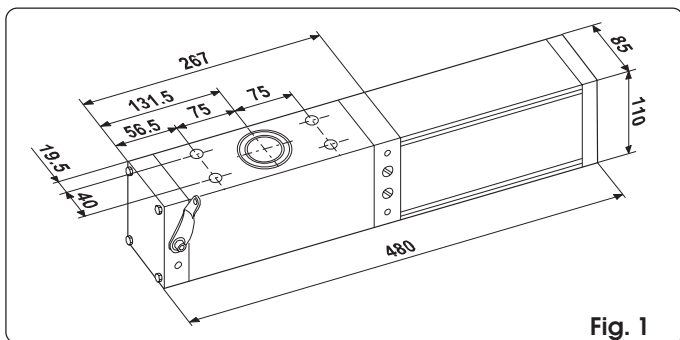

Fig. 1

## 3. TECHNICAL DATA

OPERATOR 560	
Power supply (Vac 50-60Hz)	230 (+6 -10%)
Electric motor	single-phase induction 1450 rpm
Maximum absorbed power (W)	220
Absorbed current (A)	1
Thrust capacitor (µF)	8
Winding thermal protection (°C)	120
Maximum cycles/hour	80
Protection class	IP54
Operating ambient temperature (°C)	-20 / +55
Max weight of gearmotor (Kg)	12
Type of oil	FAAC HP OIL
Oil quantity (l)	1.2

	TYPE OF OPERATOR		
	560 CBAC	560 SB	560 rap. CBACR
PUMP FLOW RATE l/min.	1,0	1,0	1,5
ANGULAR VELOCITY °/sec.	12,4	12,4	18,6
MAXIMUM TORQUE Nm	320	320	230
HYDRAULIC LOCK	YES	NO	YES
PANEL MAX WIDTH m	1.50	2.00	0.5

The fast version (CBACR) is recommended for doors with the width of every single leaf of not less than 0.5 m.

The hydraulic lock is a special hydraulic function which guarantees the door to lock when closing without having to use an electric lock (maximum leaf dimensions: 1.5 m).

However, all models are supplied with a release device to facilitate (in the SB type) or enable (in the CBAC and CBACR types) manual opening or closing of the door.

In the SB version, an electric lock must be installed to ensure the closing and/or opening position is maintained.

## 4. ELECTRICAL CONNECTIONS

**IMPORTANT: arrange for the system to be earthed according to current legal regulations.**

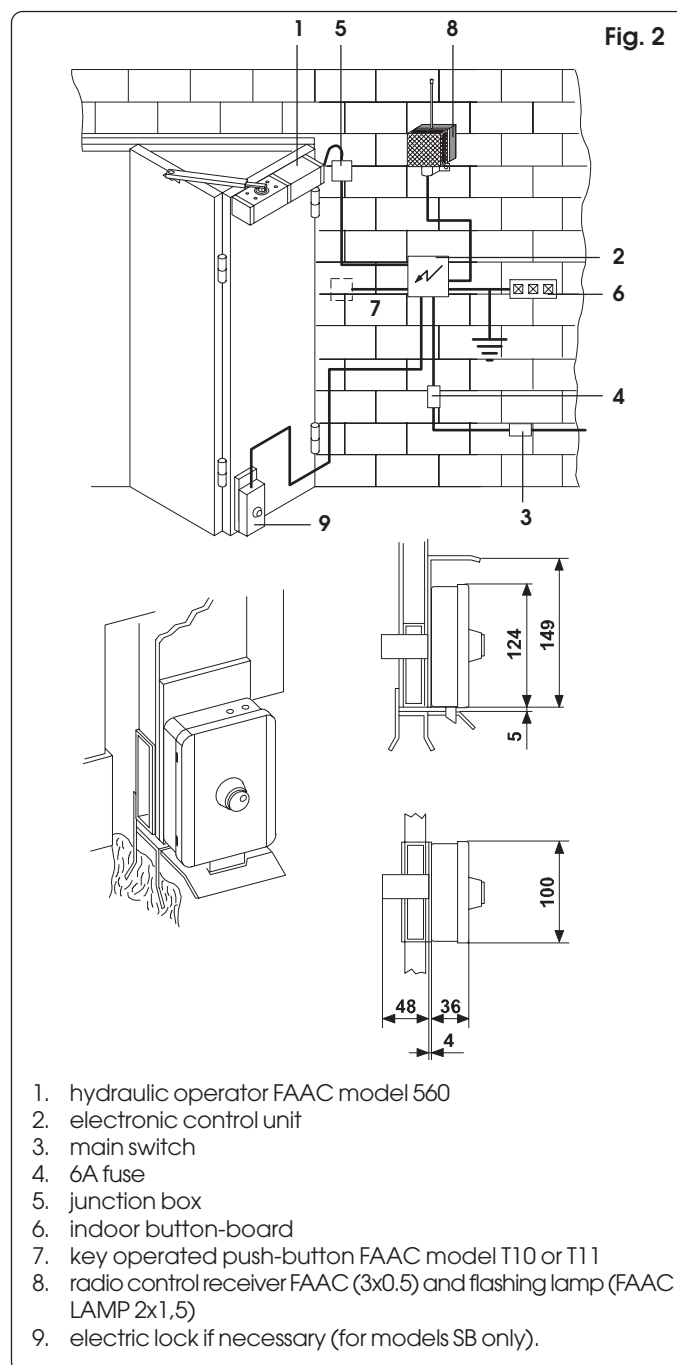

The number and selection of the electric conductors are indicated in the drawing. The sections must be adequately increased for lengths of over 100 meters.

Keep the control and power cables separated.

We recommend installing a pair of FAAC Fotoswitch photocells (fit them internally, in line with the door jamb) and/or a pneumatic safety edge (fit it on the door profile).

In the first case, use 3 cables with 0.5 mm<sup>2</sup> section for the receiver, and 2 cables with 0.5 mm<sup>2</sup> section for the transmitter. In the second case, install a pressure switch, with the relevant pneumatic connection pipe and 2 cables with 0.5 mm<sup>2</sup> section.

To connect an electric lock, if any, use 2 cables with 1.5 mm<sup>2</sup> section. For the connection and installation lay-outs of the control unit, for the pulse generators, for the safety and signalling accessories, and for the electric lock, refer to the specific instructions enclosed with each product.

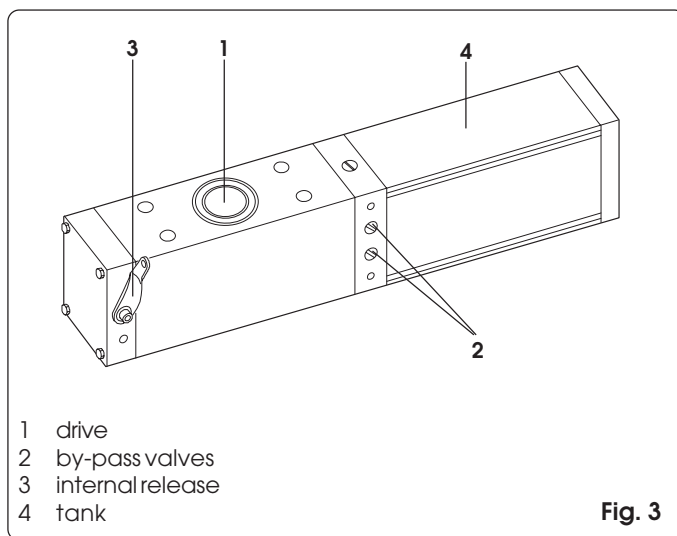

#### 4. TECHNICAL SPECIFICATIONS FOR THE FAAC 560 OPERATOR AND SPECIFICATIONS FOR INSTALLING IT ON FOLDING LEAVES.

##### Operator installation procedure (fig. 4)

- Install the operator on the leaf (5.3) hinged directly on a pillar or wall.
- Position the door as in fig. 4d; (door open). Dimension A, i.e. the distance between the rotation axis of the operator shaft and the rotation axis of the hinges (5.2) must be about 12 cm (MIN 6, MAX 16).
- When you decide the position of the operator, make absolutely sure that the by-pass valves (6.12) are always visible. To install on right or left, overturn the operator, but always keep the valves at the front.
- Weld the brackets (6.10) on the top of the door in their exact position, in order to obtain the preset dimension A.
- Fasten the operator to the brackets with the screws (6.9).
- Release the operator with lever 6.13 (rotating it anti-clockwise), fit the square 6.8 - on which the arm 6.6 is already secured - on the rotation centre (6.11).
- Rotate the arm 6.6 in the door opening direction, until it stops and then rotate it by 5° in the opposite direction.
- Define the position at the mid-point of leaf 5.4 and secure, in this position, the corner 6.7, with the pin for fastening the telescopic arm (by Seeger ring).
- If necessary, shorten the telescopic arm (both the elements, sheath (6.5) and internal element (6.6) of the same quantity), so that you can install the telescopic arm on the pin 6.7 (leave about 5 cm between sheath and telescope end as shown in fig. 4d).

- Check if the door opens and closes completely and if the two elements of the telescope remain engaged for a sufficient distance (at least 20 cm) in the less advantageous position (closing).
- Grease the telescope and front pin.
- Remove the breather screw (6.3) from the top of the operator. Take the lever (6.13) back into the hydraulic lock position (turning it clockwise). Locate the operator power cable and make the electrical connections.

##### The door (fig. 5)

- The door must have two or four leaves (units of two leaves for each part).
- They may be of any material providing the structure is rigid.
- The hinges (5.1, 5.2) must not have too much friction or clearance - the latter condition is essential to ensure optimum system operation.

##### Top guide and sliding bearing-roller (fig. 6)

- The door must have a top guide (6.1) (or a bottom guide) and a roller (6.2) which, in relation to the dimensions and weight of the leaves, must bear the leaves in addition to guiding them, thus reducing the load on the hinges (5.1, 5.2).
- After closure, the two leaves must always rest on a top stopping point (6.4) of the same width as the door.

##### Adjustment of the by-pass valves (6.12)

- One of the two screws adjusts closing thrust, the other screw adjusts the opening thrust. clockwise rotations increase the thrust, and anti-clockwise rotations reduce it. These very sensitive valves influence the operator's pressure (thrust) and neither do they adjust speed, nor influence the hydraulic lock. While you restrain the door with your hands, check the thrust supplied by the operator and then adjust in order to obtain a sure movement, without any uncertainties.

The release system has a sprung return and, therefore, it is sufficient to release the cable to automatically lock the operator.

A key operated lock is available for commanding the release system from the outside (square of fig.6).

The operators without a hydraulic lock also have a manual release to facilitate leaf movement in case of a power cut.

Figure 6 shows how to connect the key operated outside release system (optional) by a cable to the release lever 6.13.

To release internally, fit the cable supplied in the operator package on the release lever 6.13.

If there is not sufficient space for the operator in open position behind the door, an installation exactly symmetrical with respect to the one we have just described can be made: in this case, install the operator on the more external leaf (leaves 5.4 in fig.5) and install the corner of the pin 6.7 on the leaf which is directly hinged on the wall or pillar (leaves 5.3 in fig.5). For the rest of the installation, proceed as above.

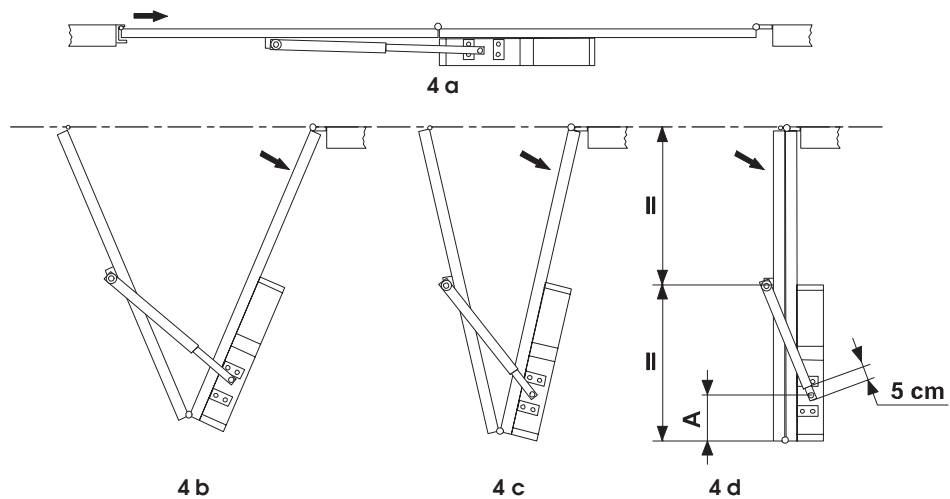

Fig. 4

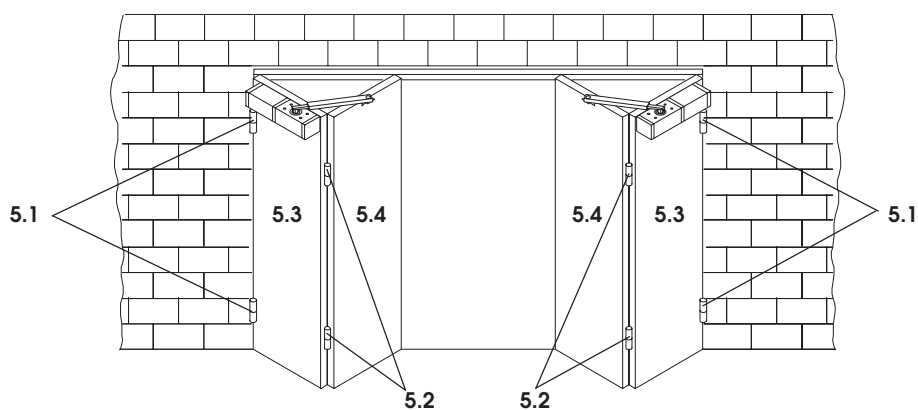

Fig. 5

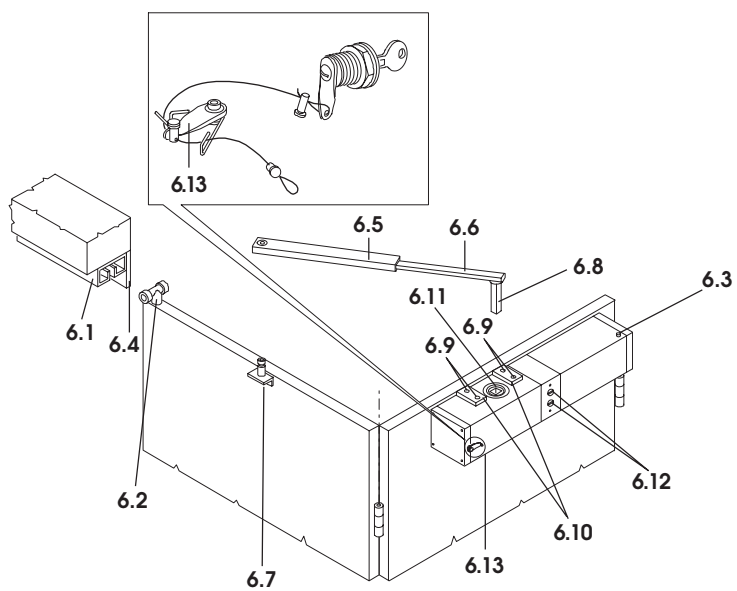

Fig. 6

Le descrizioni e le illustrazioni del presente manuale non sono impegnative. La FAAC si riserva il diritto, lasciando inalterate le caratteristiche essenziali dell'apparecchiatura, di apportare in qualunque momento e senza impegnarsi ad aggiornare la presente pubblicazione, le modifiche che essa ritiene convenienti per miglioramenti tecnici o per qualsiasi altra esigenza di carattere costruttivo o commerciale.

The descriptions and illustrations contained in the present manual are not binding. FAAC reserves the right, whilst leaving the main features of the equipments unaltered, to undertake any modifications it holds necessary for either technical or commercial reasons, at any time and without revising the present publication.

Les descriptions et les illustrations du présent manuel sont fournies à titre indicatif. FAAC se réserve le droit d'apporter à tout moment les modifications qu'elle jugera utiles sur ce produit tout en conservant les caractéristiques essentielles, sans devoir pour autant mettre à jour cette publication.

Die Beschreibungen und Abbildungen in vorliegendem Handbuch sind unverbindlich. FAAC behält sich das Recht vor, ohne die wesentlichen Eigenschaften dieses Gerätes zu verändern und ohne Verbindlichkeiten in Bezug auf die Neufassung der vorliegenden Anleitungen, technisch bzw. konstruktiv/kommerziell bedingte Verbesserungen vorzunehmen.

Las descripciones y las ilustraciones de este manual no comportan compromiso alguno. FAAC se reserva el derecho, dejando inmutadas las características esenciales de los aparatos, de aportar, en cualquier momento y sin comprometerse a poner al día la presente publicación, todas las modificaciones que considere oportunas para el perfeccionamiento técnico o para cualquier otro tipo de exigencia de carácter constructivo o comercial.

De beschrijvingen in deze handleiding zijn niet bindend. FAAC behoudt zich het recht voor op elk willekeurig moment de veranderingen aan te brengen die het bedrijf nuttig acht met het oog op technische verbeteringen of alle mogelijke andere productie- of commerciële eisen, waarbij de fundamentele eigenschappen van de apparaat gehandhaafd blijven, zonder zich daardoor te verplichten deze publicatie bij te werken.



# FAAC

**FAAC S.p.A.**  
Via Benini, 1  
40069 Zola Predosa (BO) - ITALIA  
Tel.: 051/61724 - Fax: 051/758518  
[www.faac.it](http://www.faac.it)  
[www.faacgroup.com](http://www.faacgroup.com)



Timbro del Rivenditore:/Distributor's Stamp:/Timbre de l'Agent:/ Fachhändlerstempel:/Sello del Revendedor:/Stempel van de dealer: